

# MINIMATIC Mini



+ Stainless steel self-tap

## TECHNICAL FEATURES

Fruits per minute	15
Feeder capacity	8 Kg / 17,6 Lbs
Feeder mode	Automatic
Squeezing diameter	60-80 mm / 2,36-3,15"
Waste bin capacity	In the stand
Weight	89,4 Kg / 197 Lbs
Voltage	230 V - 50/60 Hz 115 V - 60 Hz
Energy consumption	3,7 A / 4,1 A 8,1 A
Power	550 W - 0,7 Hp
Protection	Security and locking detectors. IPx4

Recommended consumption Moderate

Medium

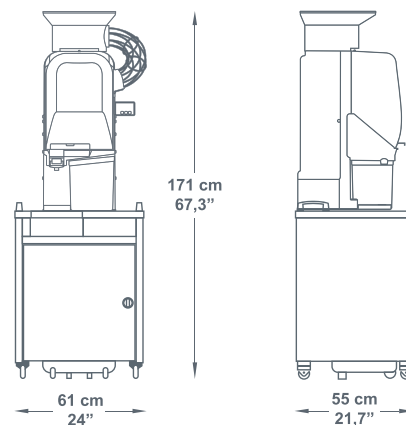

## COLORS



## Mini Stand



Support specially designed for self-service mode and moderate to medium consumption. The cabinet is equipped with a big waste bin for the peels.

Waste bin capacity	50 Kg / 110 Lbs / 300 squeezed oranges approx.
--------------------	--